



A22040



Ringlight, A22040 with Retaining Ring

A22050



Ringlight, A22050

58 mm Ringlights

Designed to fit Nikon SMZ and Leica S4E and S6E microscopes.

Standard Features

- Working distance is 1.5" to 6" (38 to 152).
- 33" (838) bundle length on all models.
- The ringlight body is made of rugged, black anodized aluminum and the fiber bundle is protected with flexible PVC covered metal tubing except the ESD (Electro Static Discharge) models.
- ESD ringlights are made conductive by replacing the black anodized finish with an irridited finish and the PVC metal tubing with stainless steel tubing. Each ringlight is checked for conductivity from inner body to light source adapter.
- Vertical exit bundle increases work space and prevents the bundle from interfering with surrounding objects.
- Retaining ring mounting for the A22040 ringlight offers secure positioning.
- Thumbscrew clamping/mounting system for precise positioning on the A22050 & A22060 models. Ringlights fit directly onto microscope and camera objectives without adapters.
- A22050 and A22060 ringlights will fit on all auxiliary lenses for the S4E and S6E microscopes.
- Input fits all ColdVision light sources. Ringlights can be used with other manufacturer's light sources. Adapters may be required.
- Use ringlights with our Dichroic color filters, diffusers, polarizer/analyzers, and reflector rings for alternative lighting effects.
- Modified standard and custom ringlights are also available for all your unique requirements.
- Manufactured in the USA.

58 mm Ringlights

Part No.	ESD	Objective Diameter	Mounting System	Polarizer/Analyzer
A22040		Nikon SMZ 645/660	Retaining Ring	A22042
A22050		Leica S4E/S6E	Thumbscrew	A22052
A22060	X	Leica	Thumbscrew	A22052

RINGLIGHTS

58 mm Ringlights

Dimensions in () are in mm

Ringlight Input: Black Anodized Aluminum or Irridited Finish

Bundle Sheathing: PVC Covered Metal Tubing or Stainless Steel

Working Distance: 1.5" to 6" (38 to 152)

Warning: This product is manufactured with glass fiber. Not for use in cable/hose carrier. Call SCHOTT to discuss moving cable/hose carrier applications.

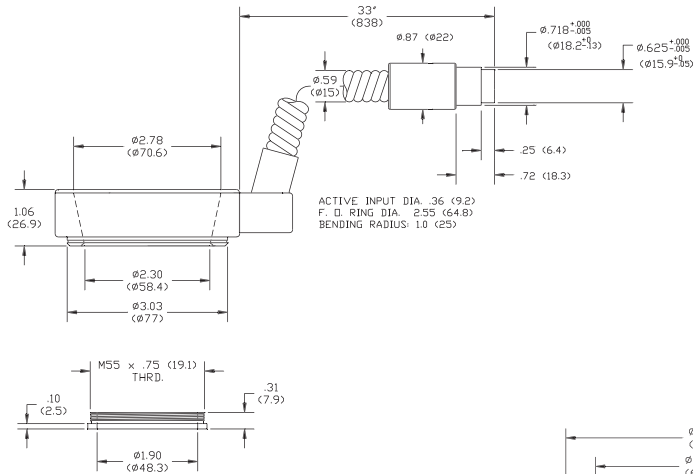

A22040 - Ringlight with Vertical Exit and Retaining Ring for Nikon SMZ 645/660 Microscopes

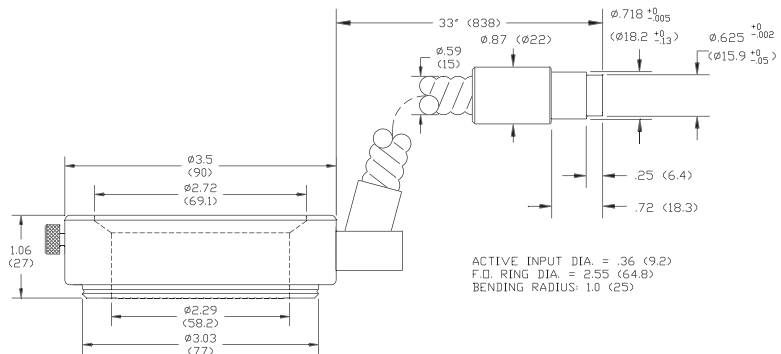

A22050 - Ringlight with Vertical Exit for Leica S4E/S6E Microscopes

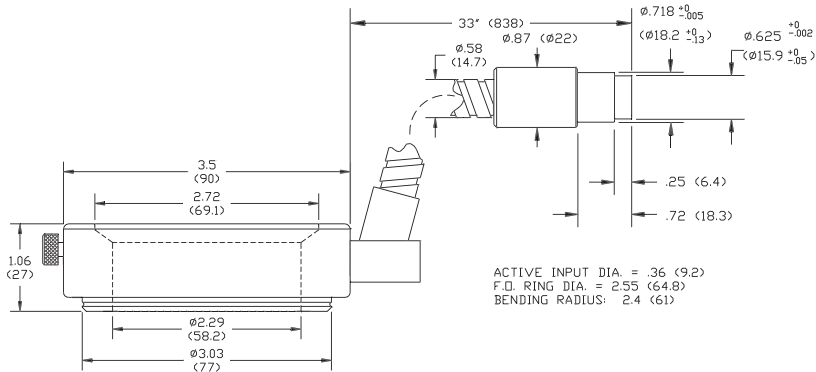

A22060 - ESD Ringlight with Vertical Exit for Leica S4E/S6E Microscopes

TECHNICAL SPECIFICATIONS

Fiber Optics

SCHOTT North America, Inc.

62 Columbus Street

Auburn, NY 13021-3137

USA

Phone: +1315/255-2791

Fax: +1315/255-2695

E-mail: fiberoptics.auburn@us.schott.com

www.us.schott.com/fiberoptics

SCHOTT